

**90° Die Stamped Flangeless Elbow**  
**Galvanized (DSE90)**  
**Galvaneal (NDSE90)**

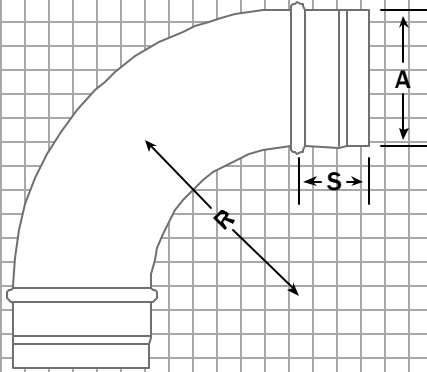

**45° Die Stamped Flangeless Elbow**  
**Galvanized (DSE45)**  
**Galvaneal (NDSE45)**

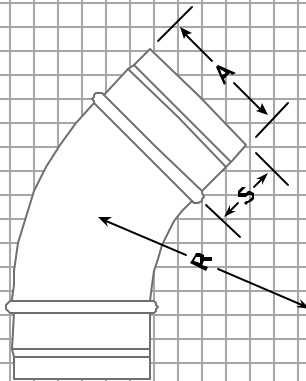

**Key**

A = Diameter  
 R = 1-1/2 A (centerline radius)  
 S = 2"

**Materials Available**

- Galvanized (3" to 7") 24 gauge
- Galvanized (8" to 12") 22 gauge
- Galvaneal (paint grip) (5" to 12") 22 gauge

**Welding Process**

Flangeless elbows are continuously stitch welded on the throat and heel from end to end (past the bead).

**Dimensions**

Size	(A)	90° (R)	Wt. Per 90° Elbow (DSE90)	Wt. Per 90° Elbow (NDSE90)
3"	2-7/8"	4.5"	0.8#	0.8#
4"	3-7/8"	6.0"	1.4#	1.4#
5"	4-7/8"	7.5"	1.8#	2.5#
6"	5-7/8"	9.0"	2.2#	3.4#
7"	6-7/8"	10.5"	3.5#	4.4#
8"	7-7/8"	12.0"	4.7#	5.4#
9"	8-7/8"	13.5"	6.1#	5.9#
10"	9-7/8"	15.0"	7.6#	6.4#
12"	11-7/8"	18.0"	10.2#	9.0#

Size	(A)	45° (R)	Wt. Per 45° Elbow (DSE45)	Wt. Per 45° Elbow (NDSE45)
3"	2-7/8"	4.5"	0.6#	0.6#
4"	3-7/8"	6.0"	0.8#	0.8#
5"	4-7/8"	7.5"	1.0#	1.5#
6"	5-7/8"	9.0"	1.5#	2.0#
7"	6-7/8"	10.5"	1.8#	2.6#
8"	7-7/8"	12.0"	3.0#	3.2#
9"	8-7/8"	13.5"	3.5#	4.0#
10"	9-7/8"	15.0"	4.2#	4.8#
12"	11-7/8"	18.0"	6.5#	6.6#